

Earthquake

MAKE A SEISMOGRAPH

Purpose/hypothesis

In this experiment, you will construct a simple seismograph and simulate the forces that cause an earthquake. Your seismograph is a simple model, but you will see if it can detect vibration in your house or building.

Do you think a seismograph would be useful in the Cairns region? Why?

You probably have an educated guess about the outcome of this experiment based on what you already know about earthquakes. This educated guess, or prediction, is your hypothesis.

A hypothesis should explain these things:

- ▶ The topic of the experiment
- ▶ The variable you will change
- ▶ The variable you will measure
- ▶ What you expect to happen.

A hypothesis should be brief, specific, and measurable. It must be something you can test through observation.

Your experiment will prove or disprove whether your hypothesis is correct. Here is one possible hypothesis for this experiment: "By simulating an earthquake with various types of disturbances, I will detect and record various types of vibrational activity on my seismograph."

In this case, the variable you will change is the amount of simulated earthquake disturbance, and the variable you will measure is the amount of displacement recorded on your seismograph. If a greater simulated disturbance results in a greater displacement on your seismograph, you will know your hypothesis is correct.

Variables are anything that might affect the results of an experiment. Here are the main variables in this experiment:

- ▶ The amount of simulated earthquake disturbance
- ▶ The distance of the disturbance from the seismograph
- ▶ The surface on which you place your seismograph.

In other words, the variables in this experiment are everything that might affect the amount of disturbance recorded on your seismograph.

If you change more than one variable, you will not be able to tell which variable had the most effect on the seismograph recordings.

Time for this activity

Allow one hour

Materials needed

- ▶ 1 or 2 helpers
- ▶ Cardboard box about 30cms x 30cms with an opening on top
- ▶ Scissors
- ▶ Ruler
- ▶ Adding machine tape or similar
- ▶ String
- ▶ Pencil
- ▶ 5-ounce (about 148-millilitre) paper cup
- ▶ Masking tape
- ▶ Black marking pen
- ▶ Small rocks or marbles
- ▶ Modelling clay

Instructions

1. Turn the box on its side so the opening is facing outward.
2. Cut a 5-centimetre circle in the centre of the top side of the box.
3. Cut two 1.25-centimetre x 10-centimetre slots in the box. The first slot should be in the centre of the bottom, near the front opening. The second slot should be in the back centre near the bottom.
4. Thread the adding machine tape through the slots, so the leading edge comes out the front slot.

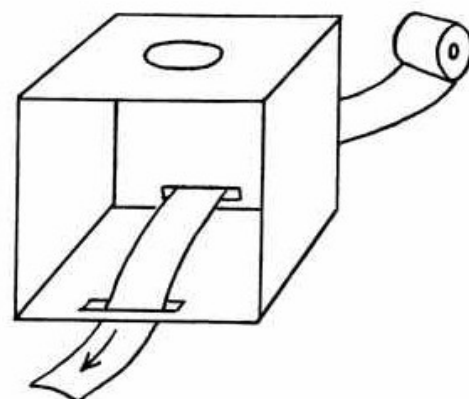

5. Cut two 61-centimetre lengths of string.
6. Use the point of a pencil to poke two holes below the rim of the cup opposite each other.
7. Tie one string onto each hole in the cup.
8. Bring the free ends of the string through

Experiment

Classroom resources provided by Cairns Regional Council



the 5-centimetre circle in the top side of the box.

9. Tape or tie the ends of the string to the pencil and lay the pencil across the hole.
10. Push the marking pen through the bottom of the cup, tip down.
11. Fill the cup with the rocks or marbles.
12. Adjust the height of the cup/pen/rock device so the marker tip just touches the adding machine tape. (You can adjust the string on the pencil, then fix the pencil in place using the modelling clay and masking tape.)

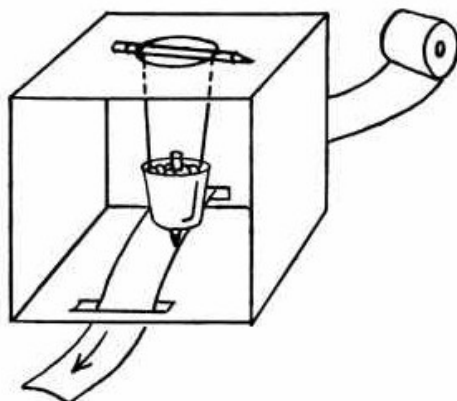

13. Test the device by pulling the adding machine tape forward with one hand and shaking the box gently with the other and observe the markings left on the paper.
14. Perform a seismic test indoors. Place your seismograph on the floor in the middle of the room. Have several of your friends walk, skip, jog, and run around in the room in a circle, always keeping the same distance away from the seismograph. While they are moving about, record the seismic waves, or seismic activity, by slowly pulling the adding machine tape through the instrument (see illustration).
15. Label the tape with the location and activities.

Summary of results

Compare your tapes. Do they show greater movement when the activity was more vigorous? In other words, does your seismograph accurately detect and record seismic activity? Experiments do not always work out as planned.

Below are some problems that may arise during this experiment, some possible causes, and ways to remedy the problems.

Problem 1: Nothing is being recorded on the adding machine tape.

Possible cause: The pen is not touching the tape.

Adjust the height of the marker pen. Gently shake the box and pull the tape until a mark appears.

Problem 2: The adding machine tape does not move easily through the slots.

Possible cause: The slots are too small. Enlarge the slots to allow the tape to move freely.

Problem 3: The model works during the test, but when your friends run or jump, nothing happens.

Possible cause: Your friends are not making strong enough vibrations. Have them jump up and down. If that doesn't work, have them move closer to the seismograph.

Change the variables

You can change one of the variables and repeat this experiment. For example, you can have your friends move closer or farther away from the seismograph to determine how the recordings vary. You can also place the seismograph on a shaky table, like an old card table, to see if this amplifies the disturbances.

Be sure to change only one variable at a time. Otherwise, you will not be able to determine which variable affected the results.

Discuss

What need do we have for a seismograph in the Cairns region? How would we use the information it generated?

Curriculum links

11 & 12	Earth & Environmental Science	ACSES098: Science understanding; The cause and impacts of earth hazards	Earth hazards result from the interaction of Earth systems and can threaten life, health, property, or the environment; their occurrence may not be prevented but their effect can be mitigated.
	Earth & Environmental Science	ACSES099: Science understanding; The cause and impacts of earth hazards	Plate tectonic processes generate earthquakes, volcanic eruptions and tsunamis; the occurrence of these events affect other Earth processes and interactions (eg ash clouds influence global weather).
	Earth & Environmental Science	ACSES100: Science understanding; The cause and impacts of earth hazards	Monitoring and analysis of data, including earthquake location and frequency data and ground motion monitoring, allows the mapping of potentially hazardous zones, and contributes to the future predictions of the location and probability of repeat occurrences of hazardous Earth events, including volcanic eruptions, earthquakes and tsunamis
	Geography	ACHGE013: Geographical knowledge and understanding; overview of natural and ecological hazards	The concept of risk as applied to natural and ecological hazards